Journal of Materials Science



CHAPMAN AND HALL

Journal of Materials Science is an international publication reporting recent advances in all the major fields of investigation into the properties of materials. Papers and letters on metallurgy, ceramics, polymers, electrical materials, biomaterials, composites, and fibres appear regularly.

Papers for submission to the *Journal of Materials Science* should be sent to Professor W. Bonfield, Dept. of Materials, Queen Mary College, Mile End Road, London E1 4NS.

Journal of Materials Science is published monthly by Chapman and Hall Ltd., 11 New Fetter Lane, London EC4P 4EE, from whom subscription details are available.

Relationship between geometric and physical structure and properties of granular composites

R. A. BARES

Institute of Theoretical and Applied Mechanics, Czechoslovak Academy of Sciences, Prague 2, Czechoslovakia

The majority of contemporary methods used in the predictions of the deformation behaviour of non-homogeneous materials as a response to external loads (similarly in the case of various physical characteristics) concern composites of the first type [1], i.e. compact systems consisting of a matrix with segregated solid particles. Various quasi-homogeneous and quasi-isotropic models of compact materials are used and the structural aspects are considered at most by empirical modifications of relations obtained. The introduction of the actual geometrical structure or at least of an adequate structural model, together with the physical properties of the components, into the description of the composites, particularly composites of the second and third types (with aggregated solid particles, with or without fluid phase, either continuous or discrete) [1] has not been customary so far, although it is impossible to expect a good agreement of theoretical and actual results without it. This paper analyses, on the one hand, adequate models of quasi-homogeneous compact composites and presents, on the other hand, structural models of composite materials (both compact and incompact, [2, 3]), enabling the introduction of the effects of both the geometrical arrangement of the structure and the interphase interactions, including the effects of external environment.

1. Quasi-homogeneous and quasi-isotropic models of compact materials

The majority of relationships describing the elasticity and various other properties (thermal conductivity, permittivity, etc.) of Type I composite is based on the model of suspension of a Newtonian viscous fluid using solid spheres, as a rule [4-12]; the equations of hydrodynamics and elasticity for high ratios of shear moduli G_p/G_m (corresponding to the case of dispersion of solid particles p in a yielding matrix m), assuming perfect bond (along the whole interface) are analogous*, only η being replaced by E .

For the prediction of the behaviour of the

composites the variation methods seem to be most promising, since they enable, to a certain extent, to include both geometric and physical factors.

If it is not possible to determine whether the phase is continuous or dispersed or, in the case of a continuous phase, the extent of phase continuity, two extreme quasi-homogeneous and quasi-isotropic models of phase arrangement can assist at least an informed assessment of mutual phase interaction and its influence on the properties of a compact (pore-free) composite, namely: (a) parallel model (the so-called hard system); and (b) series model (the so-called soft system); differentiated in accordance with the direction of the

*Analogous relations have been deduced for various other systems, e.g. for solid ellipsoid inclusions in a viscous matrix [13] (with the possibility of modelling spherical, tabular as well as fibrous shapes of dispersed particles), for elastic spheres in a viscous matrix [14], for solid spheres in an elastic matrix [15-17], for elastic spheres in an elastic matrix [18-20], for spherical pores in an elastic matrix [21], for spherical pores in a solid (brittle) matrix [22], for inclusions or pores surrounded by a matrix shell [21] or by a transition layer [15, 23, 24], etc.

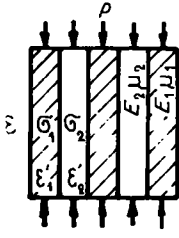

Figure 1 Parallel (hard) and series (soft) model of a composite compact material (with equal axial deformations or equal axial stresses). ϵ = longitudinal deformation, σ = stresses, ϵ' = transverse deformation.

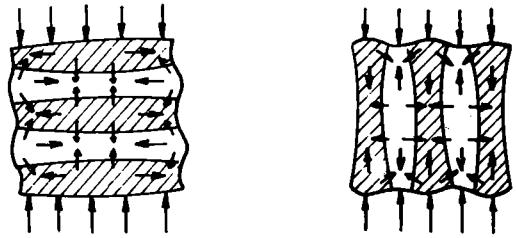

Figure 2 Model of real system with stresses induced in phases.

stresses in respect of the direction of the layers (Fig. 1).

In the parallel (hard) model the contact surfaces are characterized by equal axial strains of both phases (and extreme shear stresses), in a series (soft) model by equal stresses (without shear stresses). An elastic strain of a *real* quasi-homogeneous system lies between the extremes represented by the models and includes a number of distortions and rotations from shear stresses of the phases (Fig. 2).

If we observed elastic deformability of the extreme models under load (characterized by the moduli of elasticity E_1, E_2 and the Poisson coefficients μ_1, μ_2 of the components and their volume quotas V_1, V_2) we obtain, in accordance with [2] for the parallel system consisting of two phases:

$$\mu_s^h = \frac{\mu_1(1 + \mu_2)(1 - 2\mu_2)V_1E_1 + \mu_2(1 + \mu_1)(1 - 2\mu_1)V_2E_2}{(1 - \mu_2)(1 - 2\mu_2)V_1E_1 + (1 + \mu_1)(1 - 2\mu_1)V_2E_2} \quad (1)$$

$$E_s^h = \frac{[(1 + \mu_2)V_1E_1 + (1 + \mu_1)V_2E_2][(1 - 2\mu_2)V_1E_1 + (1 - 2\mu_1)V_2E_2]}{(1 - \mu_2)(1 - 2\mu_2)V_1E_1 + (1 + \mu_1)(1 - 2\mu_1)V_2E_2}$$

Similar relations were deduced in [25]. Analogously we obtain for the series system

$$\frac{1}{E_s^s} = \frac{V_1}{E_1} + \frac{V_2}{E_2} \quad (2)$$

$$\mu_s^s = \frac{\mu_1V_2E_2 + \mu_2V_1E_1}{V_1E_2 + V_2E_1}$$

Similarly for a volume modulus of a compact system the limits

† Sometimes the experimental values agree with other, mostly empirically derived functions, such as $E_s = \frac{1}{2}(E_s^s + E_s^h)$ or

$$\log E = \frac{1}{2}(\log E_s^s + \log E_s^h).$$

$$K_s^s = \frac{1}{3} \frac{E_1E_2}{(1 - 2\mu_1)V_1E_2 + (1 - 2\mu_2)V_2E_1} \quad (3)$$

$$K_s^h = \frac{1}{3} \frac{(1 - 2\mu_1)(1 - 2\mu_2)}{(1 - 2\mu_2)V_1E_1 + (1 - 2\mu_1)V_2E_2}$$

hold. See Appendix A.

These formulae show at first sight, for example, that the difference of the moduli of both phases exercises a far greater influence in the series system than in the parallel system, and that the properties of the series system are determined more or less by the less solid component. In an actual system the phase relationship varies in accordance with the modifications of the volume representation of the components. The continuity of one or the other phase may prevail and the physical properties of the system, therefore, will lie somewhere between the extremes mentioned above.

It has been proved [2, 32] that the elastic

strain of every concrete compact system, taking place on the principle of minimum elastic strain energy, remains a compromise between its hard and soft behaviour. If shear stresses are eliminated from the description, it holds for every physical constant that

$$\frac{1}{C_s} = \frac{1}{2} \left[\frac{1}{C_s^s} + \frac{1}{C_s^h} \right] \quad (4)$$

or, specifically for the modulus of elasticity E ,

$$E_s = \frac{2(E_s^sE_s^h)^\dagger}{E_s^s + E_s^h} \quad (5)$$

for Poisson's coefficient

$$\mu_s = \frac{\mu_s^h E_s^s + \mu_s^s E_s^h}{E_s^s + E_s^h} \quad (6)$$

and for the volume ratio K

$$K_s = \frac{2(K_s^s K_s^h)}{K_s^s + K_s^h} \quad (7)$$

The common shortcoming of the aforementioned models is the fact that their formulae describe equally the elasticity of structurally different systems, such as the system characterized by a perfect mutual interspersal of two continuous phases, a system in which one phase is dispersed in the other, or a compact system of two discrete phases. Another defect is the impossibility of replacing one of the solid phases with a fluid (gaseous or liquid) phase, which means that it is impossible to use these models for the description of porous systems.

2. Structural models of granular composites

The basic step to be taken to eliminate the above-mentioned defects is the introduction of a defined model of structure. The studies made so far have shown that it is of no importance in which way the model is defined, i.e. if it consists, for example, of spherical, cubic, ellipsoidal or other elements. The principal effect is the realization of structurality, and consequently the more probable picture of the history of stresses and strains on the one hand, and the introduction of the inner surface, without which no structural model can afford sufficient generalization, on the other hand.

In accordance with the arrangement of the filler in the system the concrete granular composites can be, generally, of dual character: the filler is in the matrix either segregated or aggregated [1]. In accordance with this circumstance the volume representation and the shape of the binder elements (bridges) of the system differ. The filler,

as a set of discrete particles, can be considered further in two boundary forms: gaseous and compact. In the first case the materials are of foam type, usually with a single solid phase; in the second case the materials consist of two or more phases with or without pore (continuous or discontinuous). These two cases are characterized, once again, by the shape of the binder elements.

An analysis of various *concrete* systems has shown that in all cases the description of a *real* system modelling them, i.e. incorporating both structurality and the inner surface, necessitates only two fundamental structural quasi-octahedral units: *a convex node* (Fig. 3) and *a concave node* (Fig. 4). (The meaning of concrete, real and ideal solid material is the same as it is currently used in liquids).

The convex node can be accepted as a basic structural element of two-phase systems of the first and the second types, both of the foam type, with separate pores (bubbles) (Fig. 5), and compact, with separate inclusions (Fig. 6), which are more yielding than matrices, and of foam-like system of the third type with interconnected bubbles, i.e. a continuously porous type (Fig. 7). The simplest case, in which the bubbles or inclusions are spherical in shape and are of equal size, can be described by *an ideal model* accurately defined geometrically. With reference to the aforementioned statement that it is not the shape, but the volume quota, together with the inner surface, that are decisive, it is possible to use:

1. for the case of discontinued porosity, i.e. separate (segregated) pore (inclusions), a simple cubic (orthogonal) skeleton[‡] constructed of cubic centres interconnected by slabs in all directions (in the selected system of Cartesian coordinates) according to Fig. 8;

2. for the case of a continuously porous system (of a foam-like type) a model according to Fig. 9 with a spatially orthogonal skeleton[§].

[‡]The selected cubic skeleton is intermediate between the extreme structural arrangements with minimum sufficient number of connecting elements in the form of a tetrahedron on the one hand and the infinite number of beams in the form of a spherical skeleton on the other hand.

[§]The bubbles of equal size of the void (or yielding) phase are assumed in the corners of the cubic unit volume. This corresponds with the so-called least-density arrangement of equal spheres (in the crossing points of three planes of an orthogonal spatial network). The densest arrangement, on the other hand, is the allocation of spheres in the crossing points of four planes, oriented in accordance with the body diagonals of a cube. The spheres are then located in the corners of two tetrahedrons and one octahedron. For the case of intersecting bubbles the inter-spherical spaces would acquire the form of quasi-tetrahedras and quasi-cubes, represented at a ratio of 2 : 1, with spherically convex surfaces. With regard to the possibility of expressing the density (proportionate representation) of the bubbles by the depths of their mutual intersections at their thinnest location, it is not necessary to take this factor into account.

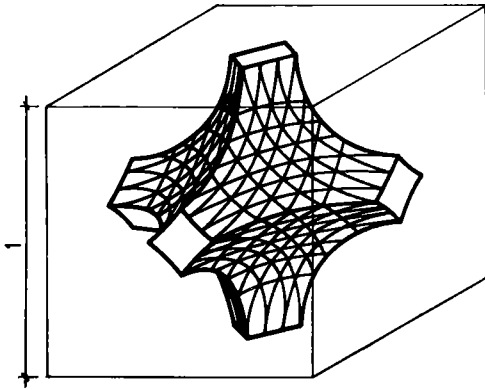

Figure 3 Convex node with solid phase half-bridges in a unit volume of a foam-like type.

In concrete foam-like systems, however, the continuous and discontinuous porosity usually exist simultaneously in the majority of cases (i.e. only some of the bubbles being interconnected). It is obvious that such a system may be considered as a compromise between the ideal systems with continuous and discontinuous porosity. In the corresponding model of a *real foam-like system* there will be, apart from the centres and beams of the spatial cross, also tabular elements (Fig. 10)[¶].

In more complex and general cases the bubbles (inclusions) may be of different size and/or a different shape. Consequently, the dimensions of the centres, beams and slabs will be different for the individual nodes and systems. While, for example, the model of an ideally continuous system (in accordance with Fig. 9) can be defined

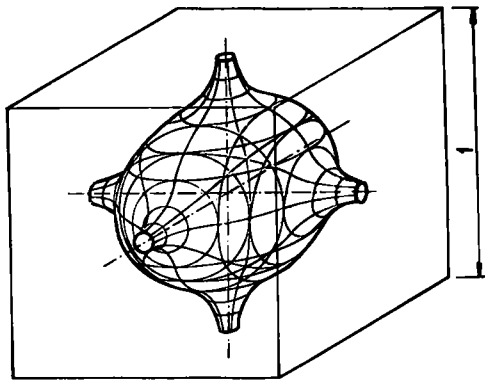

Figure 4 Concave node with solid phase half-bridges in a unit volume of a bonded filler type system.

[¶] From the discontinued porosity system (Fig. 8) as the first extreme, the gradual removal of parts of slabs makes a transition to a partly continuous porosity system, (Fig. 10) and by a complete elimination of slab components to the second extreme case, the ideal continuous system (Fig. 9).

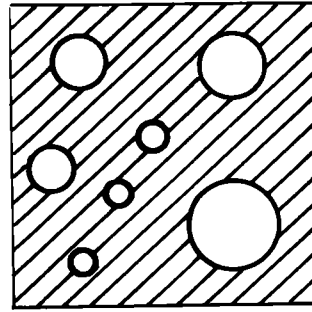

Figure 5 Foam-like material with separated pores.

by a relative linear dimension of the cubic centre (and of the cross-section of the beams) a referred to the linear dimension of the cubic system (the enveloping cube), in a general case the describing quantities will be statistical functions, i.e. the sizes of the centres, beams, enveloping cube and, consequently, the partial volumes and inner surface. For the further calculations of, for instance, the elastic characteristics of the system either these functions, or – more simply – their mean values will be used.

For an ideal model the volume of the centre is

$$V_c = a^3 \quad (8)$$

the volume of the beam

$$V_b = 3a^2(1-a) \quad (9)$$

and the whole volume of the skeleton

$$V_k = a^2(3-2a) \quad (10)$$

from which

$$a = \frac{1}{2} + \cos \frac{1}{3} \arccos(1-2V_k). \quad (11)$$

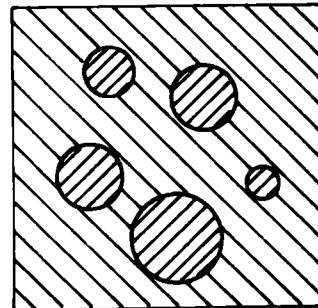

Figure 6 Compact system with separated yielding inclusions.

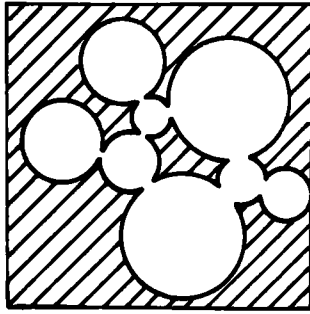

Figure 7 Foam-like material with interconnected pores.

The cross-section of the centre and the area of the surface of intersection of the beams with the surface of the system (equal to cross-section of the beam) is

$$A_c = A_b = a^2 \quad (12)$$

Modulus of elasticity E_s and Poisson's coefficient μ_s of an ideal continuously porous system (of a foam-like type) using the combination of hard and soft behaviour (in the sense of the foregoing definitions) according to Equation 5 and 6 is:

$$E_s = \frac{6E_a^2}{6-C} \quad (13)$$

$$\mu_s = \frac{3\mu - D + 3a\mu}{6-C} \quad (14)$$

where

$$C = 2(1-a)[(1-2\mu)(1-A) + 2(1-\mu)(1-B)],$$

$$D = 2(1-a)[(1-2\mu)(1-A) - (1+\mu)(1-B)],$$

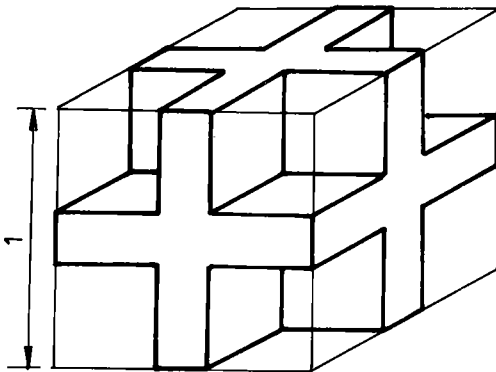

Figure 8 Unit volume of an ideal discontinuous porosity system of a foam-like type.

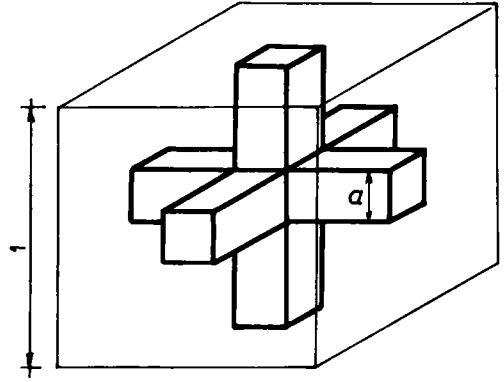

Figure 9 Unit volume of an ideal continuous porosity system.

$$A = \frac{2(1-\mu)(1-a)}{2(1-2\mu) - a(1-3\mu)},$$

$$B = \frac{2(1-\mu)(1-a)}{(2-\mu) - a} \quad (15)$$

and E and μ are elasticity constants of the material of the skeleton. Should the skeleton consist of more than one phase, the elasticity constants are obtained from Equations 1 and 2 by the mixing of the properties of the components using Equation 5 or Equation 6, respectively. (See also Appendix B).

Analogously it is possible to determine the elastic constants also for the model of discontinued-porosity foam-like system or the intermediate case (party continuous system), i.e. the model of a real foam-like system.

The concave node can be used as the basic structural element of two-phase systems of the second type and three-phase systems of the third type (with aggregated filler and continuous or discontinued porosity, Fig. 11). The simplest model of a real continuous porosity system is a structural

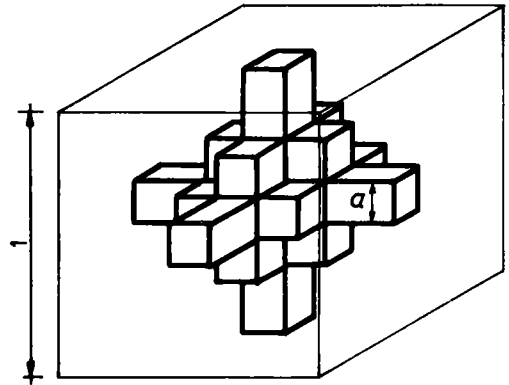

Figure 10 Unit volume of a real continuous porosity system of a foam-like type.

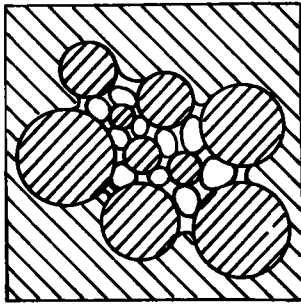

Figure 11 Schematic section of a concrete continuous porosity system of the bonded filler type.

cubic (orthogonal) unit* in accordance with Fig. 12, originating by supplementing the system in accordance with Fig. 10 with further cubic elements†. As the skeleton of this model replaces both solid phases present in the system‡, it is necessary in further considerations to work with an idealized material. It is assumed that its mechanical and elastic properties correspond with the properties of a quasi-compact material obtained in accordance with Equations 1, 2 and 4 on the basis of the properties of the components and their volume participation.

In a more accurate description it is possible to use, once again, the orthogonal model and the influence of the different shape and size of the centres and, consequently, the different sizes of the connecting bridges in the individual nodes and in the system, similarly as the influence of the changes of the inner surface (due, for instance, to the change of the surface characteristics of the filler) can be described statistically. The unit model of a real continuous porosity system of the bonded filler type (in accordance with Fig. 12) can be defined by the relative linear dimensions of the cross-section of the beam a and the centre b (with regard to the linear dimensions of the cubic system), while in a general case the describing quantities will be represented by statistical functions (size of centres, beams, enveloping cube, partial volume, inner surface) which will be used

*Similarly as in the case of porous systems of foam-like type it is not necessary to consider the location of the nodes in the case of the continuous porosity system of the bonded filler type, assuming the identity of binder and filler. The density (proportionate representation) of the solid phase (skeleton) in the system can be influenced, the size of spherical filler nodes remaining the same, by the length of binder bridges.

†It is obvious that in contradistinction from the systems of foam-like type, the continuous porosity systems cannot be considered as a compromise between, for example, the ideal continuous porosity system and a compact system. The principal reason is that in contradistinction from the foregoing there are two spherical stress elements (if the system is spherically loaded) with different principal strains.

‡The dispersed phase is concentrated in the particles modelled by the cubic centres, the matrix in connecting bridges modelled by the prisms, and the fluid phase (if present) fills the remainder of the space in the cubic system.

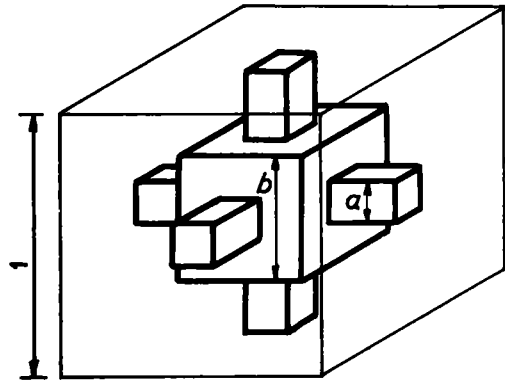

Figure 12 Unit volume of a real continuous porosity system of the bonded filler type.

for further calculations of, for instance, the elastic properties of the system either directly or by means of their mean values.

For the model of a real system, provided $a < b < 1$, it holds that the volume of the centre

$$V_c = b^3 \quad (16)$$

the volume of the beams

$$V_b = 3a^3(1 - b) \quad (17)$$

and the volume of the whole skeleton

$$V_k = 3a^2(1 - b) + b^3 \quad (18)$$

The cross-section of the centre and the beams are

$$A_c = b^2 \quad (19)$$

$$A_b = a^2 \quad (20)$$

Modulus of elasticity E_s and Poisson's coefficient μ_s of a real continuous porosity system (of the bonded filler type) are, using once again the combination of the soft and hard behaviour of the skeleton (in the meaning of the foregoing definition) according to Equations 5 and 6 respectively,

$$E_s = \frac{6Ea^2}{3 + (M - N + 2P)} \quad (21)$$

$$\mu_s = \frac{3a\mu + N + P}{3 + (M - N + 2P)}, \quad (22)$$

where

$$\begin{aligned}
 M &= 3(1-b) \frac{(1+\mu)(1-2\mu)}{1-\mu} \\
 N &= (1-2\mu) \left\{ \left[(1-b) \frac{2\mu}{1-\mu} - a \right] (1-Q) + \frac{a(b-a)}{b} (1-R) \right\} \\
 P &= (1+\mu) \left\{ \left[(1-b) \frac{\mu}{1-\mu} + a \right] (1-S) - \frac{a(b-a)}{b} (1-T) \right\} \\
 Q &= \frac{b(b^2-a^2)(1-\mu)^2 + 2a(1-b)(1-\mu)[a(1-\mu) + (b-a)(1+\mu)]}{b^3(1-\mu)^2 + 2a(1-b)(1-2\mu)[a(1-\mu) + (b-a)(1+\mu)]} \\
 R &= \frac{(a+b)(1-\mu) + 2b\mu Q}{a(1-\mu) + (b-a)(1+\mu)} \\
 S &= \frac{b(b^2-a^2)(1-\mu^2) + 2a(1-b)(1-\mu)[a(1-\mu) + (b-a)(1-2\mu)]}{b^3(1-\mu)^2 + a(1-b)(2-\mu)[a(1-\mu) + (b-a)(1-2\mu)]} \\
 T &= \frac{(a+b)(1-\mu) - b\mu S}{a(1-\mu) + (b-a)(1-2\mu)}
 \end{aligned} \tag{23}$$

and E and μ are elasticity constants obtained from Equations 1 and 2 using Equations 5 and 6 respectively by mixing the properties of the components. (See also Appendix C).

3. Interaction with external environment

All considerations and formulae derived so far hold under the assumption that the pores are not filled with yet another phase, i.e. provided the voids of the system do not transfer stresses. Actually, however, there is always a state of equilibrium between the system and its ambient environment, and the volume of continuous pores is filled with fluid phase, which obviously modifies both the elasticity constants of the system and its other physico-mechanical properties including its strength. The inclusion of interaction of the solid skeleton with the fluid phase is allowed by the inner surface of the system.

A continuous porosity system with filled pores can be considered in our further considerations as a quasi-compact two-phase system with one phase consisting of the solid skeleton and the other phase of the liquid filling its pores.

In the first extreme case with empty inner volume, the system – with regard to the possibility of free displacement of the fictitious void phase along its boundary with the solid skeleton – will be a soft one, and the elastic constants E_s , μ_s can be considered as known, determined by Relations 21 and 22 respectively. Thus the first

(lower) boundary of elastic constants of the continuous porosity systems interacting with ambient environment is determined.

In other cases, when the inner volume is filled with a liquid, it is necessary to determine first the elasticity constants of the skeleton as a phase of the system under consideration. Taking into account the assumption of the regular spatial proportionate representation of phases, and, consequently, also of the elements of the skeleton, justified by the accepted quasi-phase concept of the structure of the continuous porosity system, it follows for the modulus of elasticity of the skeleton E_k in contradistinction from the modulus of elasticity of the system in accordance with Equation 21 that

$$E_k = E[3a^2(1-b) + b^3] \tag{24}$$

or, using Equation 22,

$$E_k = EV_k \quad (V_k \leq 1) \tag{25}$$

For the volume modulus of the skeleton, analogously

$$K_k = \frac{EV_k}{3(1-2\mu)} \tag{26}$$

However, since it must hold simultaneously that

$$K_k = \frac{E_k}{3(1-2\mu_k)} \tag{27}$$

Poisson's coefficient μ_k of the skeleton obviously

equals μ of the material of which it is made, i.e.

$$\mu_k = \mu. \quad (28)$$

From Equation 2 for the soft compact system it is possible to determine, using the constants E_s and μ_s of the dry continuous porosity system and E_k , μ_k of the skeleton, the fictitious elasticity constants E_{f0} , μ_{f0} , of the *empty void phase*

$$E_{f0} = \frac{V_0(E_k - V_k E_s)}{E_s E_k} \quad (29)$$

$$\mu_{f0} = \frac{\mu_s E_k - \mu_k V_k E_s}{E_k - V_k E_s} \quad (30)$$

where V_0 is the volume of the void phase $V_0 = (1 - V_k)$.

The real value of the fictitious elasticity constants of the empty void phase shows that the elasticity of the cellular system is modified by the co-operation of the fluid phase, particularly after the liquid has entered the system from the outside environment.

In the *second extreme case* the whole interior volume will be filled with a liquid. This situation, however, occurs with a different measure of spontaneity which corresponds also with the bond of a liquid to the inner surface of the system. The first limiting case can be considered in the case of such bond of the liquid at the interphase boundary with the solid skeleton, that it makes its escape from the inner volume of the system impossible,

phase in the liquid state which solidifies in the system after it has filled the voids, e.g. polymer-impregnated concrete). Nevertheless, as soon as the soft bond be admitted (permitting mutual displacement), the flow of the liquid phase would necessarily follow.

If we consider the solid phase and the void phase as separate infrastructures, we can use the equations formerly derived for the compact system in a similar manner as for the void infrastructure. In the given case Equation 1 will be applied to the hard system consisting of the void subsystem of the volume $V_f = (1 - V_k)$, with elasticity constants E_{f0} and μ_{f0} (Equations 29, 30) and a liquid of a modulus K_f (and, under given assumptions, with $E_{fmin} = 3(1 - 2\mu_f)K_f$ and $\mu_{fmax} = 1/2$). Thus we obtain equations for elasticity constants of the *void infrastructure* (for complete and irreversible filling of voids with a liquid) as follows:

$$E_f = \frac{E_{f0}[E_{f0} + 3(1 - 2\mu_{f0})K_f]}{E_{f0} + 2(1 + \mu_{f0})(1 - 2\mu_{f0})K_f} \quad (31)$$

$$\mu_f = \frac{E_{f0} + (1 + \mu_{f0})(1 - 2\mu_{f0})K_f}{E_{f0} + 2(1 + \mu_{f0})(1 - 2\mu_{f0})K_f} \quad (32)$$

The whole superstructure of the *completely and irreversibly liquid-filled cellular system* will then have elastic properties corresponding with the hard co-operation of both infrastructures (solid and fluid) in accordance with Equation 1.

$$E = \frac{[(1 + \mu_f)V_s E_s + (1 + \mu_s)V_f E_f][(1 - 2\mu_f)V_s E_s + (1 - 2\mu_s)V_f E_f]}{(1 + \mu_f)(1 - 2\mu_f)V_s E_s + (1 + \mu_s)(1 - 2\mu_s)V_f E_f} \quad (33)$$

$$\mu = \frac{\mu_s(1 + \mu_f)(1 - 2\mu_f)V_s E_s + \mu_f(1 + \mu_s)(1 - 2\mu_s)V_f E_f}{(1 + \mu_f)(1 - 2\mu_f)V_s E_s + (1 + \mu_s)(1 - 2\mu_s)V_f E_f} \quad (34)$$

although it is a system open to the transport of the matter over its exterior boundary. In the second limiting case the liquid will not be bound to the inner surface of the system (which corresponds with its lax entry and escape into and from the system, respectively).

In the first limiting case, consequently, there must exist a hard (in the introduced meaning of the term) bond not only at the phase boundaries, but also between any adjacent molecules of the liquid, although afterwards it is hardly possible to consider the contents of the void phase of the cellular system as a liquid. (Such a case corresponds rather with a porous system filled with another

Thus we have obtained the *other (upper) boundary* of the elastic constants of continuous porosity systems interacting with ambient environment.

Explicit expressions of elastic constants of a cellular system under the influence of the liquid within the defined region can be expected to depend on the moisture content of the ambient environment and the absorption potential of the system studied, determined primarily by the contact stresses of both phases similarly as by the relation of the pore dimensions and the viscosity of the liquid.

Two examples (Figs. 13 to 15) show a comparison

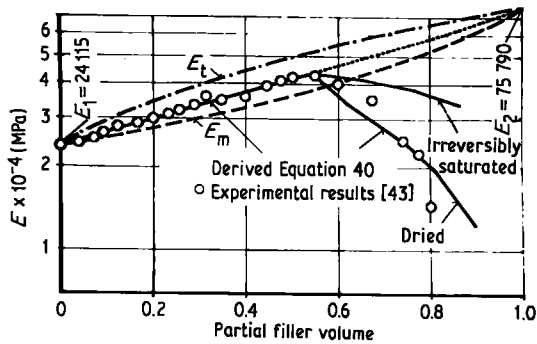

Figure 13 Hypothetical and measured values of the Young's modulus of cement mortar plotted against its composition.

of experimental results (as reported in [42] for cement mortar and in [43, 44] for polymer concrete) and theoretical values calculated in accordance with the aforementioned relationships [2] (Appendix D). Very good agreement can be observed both in the region corresponding with the first interval[§] and in the region corresponding with the third interval. In this region, the experimental values are close to theoretical values characteristic of the irreversibly saturated system for lower porosities. For higher porosities experimental values are close to theoretical values for a dry system with an empty or reversibly saturated interior volume.

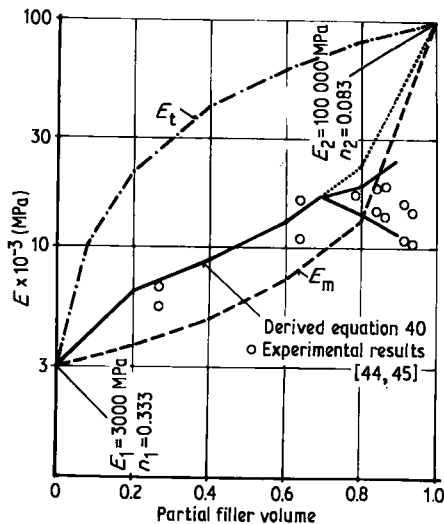

Figure 14 Hypothetical and measured values of the Young's modulus of resin concrete plotted against its composition.

[§] Equally good accordance was demonstrated in [2] by a comparison of experimental results as reported in [45, 46] for hard-ductile two-phase alloy systems with theoretical values obtained from Relationships 5 and 6 for quasi-homogenous and quasi-isotropic models of compact material.

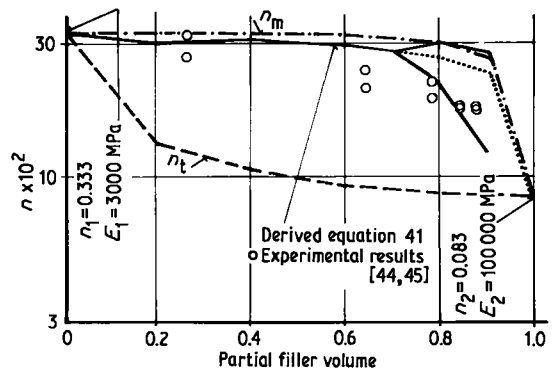

Figure 15 Hypothetical and measured value of Poisson's coefficient of resin concrete plotted against its composition.

The analysis has also shown that even for a relatively simple geometric arrangement the equations are of considerable complexity and any further "improvement", endeavouring greater accuracy is probably of no practical value, since there is a great number of further factors in every concrete material which cannot be effectively incorporated into the calculation anyway, however accurate it may be (e.g. technological factors). On the other hand the relations derived on the basis of the theory of structural continuum [2] afford more than merely quantitative results and can be used for the prediction of the behaviour of granular materials in the whole possible extent of composite arrangement, i.e. for the composites of the first as well as the third types, including their interaction with ambient environment, which no other theory has achieved so far.

Other physical properties (electrical, magnetic, thermal properties) are governed by similar laws to the elastic properties. Therefore, the adequacy of various formulation rules, particularly in the case of higher concentrations of the dispersed phase, such as are given in [4, 23, 33-36] without the introduction of structural parameters, is rather accidental; such relations should be used with caution and for the determination of informative values only. The introduction of an adequate structural model (and, consequently, of the inner surface and interphase boundaries) can yield relations for various physical properties of the composite analogous with those derived for elastic properties with a considerably higher agreement with reality.

Although the general description of the elasticity of the system has been successfully mastered, no method has been found so far which would allow a general description of the strength of granular composites of all three types[¶]. It seems however, that it is the knowledge of the deformation mechanism and the behaviour in the process of fracture and total failure that are more important for our understanding of the properties of the material rather than the absolute value of its strength which cannot be determined reliably, even in the case of homogenous materials, before a general energy theory on the basis of statistical characteristics of the material has been developed.

Appendix A

When neglecting the Poisson's coefficient $\mu_1 = \mu_2 = 0$ we obtain, as special cases, the known relations [2, 25–28] for the parallel model

$$E_s^h = E_1 V_1 + E_2 V_2$$

and for the series model

$$E_s^s = \frac{E_1 E_2}{E_1 V_2 + E_2 V_1}$$

The form of the relationships for thermal and electrical conductivity is analogous. Other models more accurate than the simple parallel and series systems have been derived by a number of authors. For example, a combination of the series and the parallel model was used for crystalline polymers [29].

Naturally, the series and the parallel models can be combined in many possible ways, which was actually done by a number of authors. These combinations usually result only in considerably more complex relations which, however, do not represent the actual structure of the material and the interactions resulting from it, and can afford agreement with experimental results in special cases only, i.e. in those for which they had been derived, as a rule. Consequently, they are of little value for a general description of structural systems. It is also possible to choose a different geometry of phases (e.g. square inclusions in the middle of the matrix [30]); of a more general use are variation procedures, e.g. [17, 31].

[¶] For some specific systems mostly empirical relationships have been derived [37–41] which, however are of very little general value. Endeavours to derive such relations theoretically have failed due to lack of knowledge of the constants or functions used in the analyses.

Appendix B

The volume modulus of such a system K_s due to outer hydrostatic pressure, i.e. if the pressure is applied to the exterior surfaces of the skeleton only, situated on the surface of the cubic system obtained by the same method is

$$K_s^{\text{ext}} = \frac{E}{3(1-2\mu)(1-F)} \quad (\text{B1})$$

where

$$F = (1-a) \frac{(1-3\mu)}{(1-2\mu)} - A$$

If, on the other hand, the hydrostatic pressure is applied to the inner surface of the skeleton (interior hydrostatic pressure), the volume modulus is

$$K_s^{\text{int}} = \frac{E}{3(1-2\mu)F} \quad (\text{B3})$$

The superposition of both effects yields the volume modulus of the system exposed to hydrostatic pressure which is the same as that for the solid phase of the skeleton or the compact (non-porous) system of the same material, i.e.

$$K_s = \frac{E}{3(1-2\mu)} \quad (\text{B4})$$

Appendix C

The volume modulus of this system K_s due to external hydrostatic pressure, i.e. if the pressure is applied to the outer surfaces of the skeleton situated on the surfaces of the cubic system, is obtained by the same procedure and is

$$K_s^{\text{ext.}} = \frac{2E}{3(1-2a\mu) + M + 3N} \quad (\text{C1})$$

If, on the other hand, the hydrostatic pressure is applied to the inner surface of the skeleton (internal hydrostatic pressure), the volume modulus is

$$K_s^{\text{int}} = \frac{2E}{6(1-2\mu) - 3(1-2a\mu) - M + 3N} \quad (\text{C2})$$

The superposition of both effects yields the volume modulus of the system exposed to hydrostatic pressure, which will be, once again, the

same as that calculated for a compact material, i.e.

$$K_s = \frac{E}{3(1-2\mu)}. \quad (C3)$$

Appendix D

For the sake of clarity we summarize the procedure used for the determination of elasticity constants of a continuous porosity system of the bonded filler type:

1. V_k, V_m, V_p relative parts of the volume of skeleton, matrix and filler respectively ($V_k = V_m + V_p$).
2. $b = V_p^{1/3}$, $a = (V_m/3(1-b))^{1/2}$ geometric parameters.
3. E, μ material of the solid phase (according to Equations 1, 2, 5, 6).
4. E_s, μ_s, V_s system with empty interior volume according to Equations 21 and 22.
5. E_k, μ_k of the skeleton according to Equations 25 and 28.
6. E_{f0}, μ_{f0} empty void phases according to Equations 29 and 30.
7. K within the limits of $\langle 0, K_f \rangle$, where K_f is the volume module of the liquid.
8. E_f, μ_f void infrastructures according to Equations 31 and 32.
9. E, μ of the system according to Equations 33 and 34.

References

1. R. A. BARES, Proceedings of the Conference on Plastics in Material and Structural Engineering, Prague, 1981, edited by R. A. Bares (Elsevier, Amsterdam, 1982) p. 254.
2. J. NAVRATIL, Mechanika spojitě porézních soustav v definovaných podmínkách prostředí, Report of ITAM-CSAS, Prague (1968).
3. R. A. BARES, J. JAVORNICKY and J. NAVRATIL, Proceedings of the Conference on Mechanical Behavior of Materials, Kyoto, 1972 (The Society of Materials Science, Japan, 1972) Vol. V, p. 42.
4. A. EINSTEIN, *Ann. Phys.* 19 (1906) 289.
5. M. MOONEY, *J. Colloid Sci.* 6 (1951) 162.
6. H. EILERS, *Kolloid. Z.* 97 (1941) 313.
7. H. C. BRINKMAN, *J. Chem. Phys.* 20 (1952) 571.
8. L. H. COHAN, *India Rubber World* 117 (1947) 354.
9. E. GUTH, *J. Appl. Phys.* 16 (1945) 20.
10. H. M. SMALLWOOD, *ibid.* 15 (1944) 758.
11. E. GUTH and L. H. COHAN, Proceedings 2nd Rubber Technical Conference, London, 1948, p. 353.
12. G. FLEMMERT, Report of Royal Institute of Technology, Stockholm, 1952.
13. G. B. JEFFERY, *Proc. Roy. Soc. (London)* 102A (1923) 161.
14. H. FRÖHLICH and R. SACK, *Proc. Roy. Soc. (London)* 185A (1946) 415.

15. E. H. KERNER, *Proc. Phys. Soc. (London)* 69B (1956) 802.
16. C. VAN DER POEL, *Rheol. Acta* 1 (1958) 1961.
17. Z. HASHIN, *Bull. Res. Council. Israel* 5 (1955) 46.
18. J. M. DEWEY, *J. Appl. Phys.* 18 (1947) 578.
19. J. D. ESHELBY, *Proc. Roy. Soc. (London)* 421A (1957) 376.
20. Z. HASHIN, in "Non-homogeneity in Elasticity and Plasticity", Proceedings IUTAM, Symposium 1958 (ed. W. Olszak), Pergamon Press, Oxford (1959) 463.
21. J. K. MACKENZIE, *Proc. Phys. Soc. (London)* 63B (1956) 2.
22. R. L. COBLE and W. D. KINGERY, *J. Amer. Ceram. Soc.* 39 (1956) 379.
23. D. A. G. BRUGGEMANN, *Phys. Z.* 37 (1936) 906, *Ann. Phys.* 29 (1937) 160.
24. J. N. GOODIER, *J. Appl. Mech.* 55 (1933) A-39.
25. B. PAUL, *Trans. AIME* 218 (1960) 36.
26. P. DANTU, Lab. Centr. du Ponts et Chaussées, Publ. No. 57-6, (1957).
27. M. F. KAPLAN, *Proc. RILEM, Paris* (1959).
28. *Idem*, *JACI, Proc.* 55 (1959) 1193.
29. M. TAKAYANAGI, *Mem. Fac. Eng., Kyushu Univ.* 23 (1963) 41.
30. U. J. COUNTO, *Mag. Concrete Res.* 16 (1964) 129.
31. Z. HASHIN and S. SHITRIKMAN, *J. Mech. Phys. Solids* 11 (1963) 127.
32. G. DOREY, G. R. SIDNEY and J. HUTCHINGS, *Composites* 9 (1978) 25.
33. J. C. MAXWELL, *Treatise on Electricity and Magnetism* 1 (1973) 365.
34. E. H. KERNER, *Proc. Phys. Soc. (London)* 69B (1956) 802.
35. J. L. NICHOLS, *J. Appl. Phys.* 26 (1955) 470.
36. A. L. LOCK, *J. Am. Ceram. Soc.* 37 (1954) 96.
37. M. GENSAMER, *Trans. Am. Soc. Metals* 36 (1940) 30.
38. E. OROVAN, Proceedings Institute of Metals Symposium on Internal Stresses (1948) 451.
39. J. C. FISHER, E. W. HART and P. H. PRY, *Acta Metall.* 1 (1953) 336.
40. F. V. LENEL and G. S. ANSELL, in "Powder Metallurgy", (ed. W. Lesynski), Interscience, New York (1961) 267.
41. A. M. BUECKE, in "Reinforcement of Elastomers", (ed. G. Kraus), Interscience, New York (1960) 5.
42. O. ISHAI, *ACI J. Proc.* 58 (1961) 611.
43. R. A. BARES, J. NAVRATIL, L. BERKA and J. JAVORNICKY, *Bull. RILEM* 28 (1965) 117, *Proc. Symp. RILEM Liège* (1964) 465.
44. J. NAVRATIL, Report ITAM. CSAS, No. 9-IX-5-4-4-3 (1964) Prague.
45. C. NISHIMATSU and J. GURLAND, Report Brown University, Division of Engineering, No. 2 (1958).
46. R. KIEFFER and P. SCHWARTZKOPF, *Hartstoffe und Hartmetalle*, Springer, Wien (1953).

Received 29 November 1983
and accepted 13 March 1984